

X8068

Versatile X-ray Inspection for Highest Demands



3D MXI

With Quality Uplink!

Fast, Convenient, High Performance

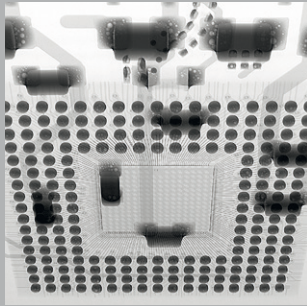

BGA overview under angled radiation

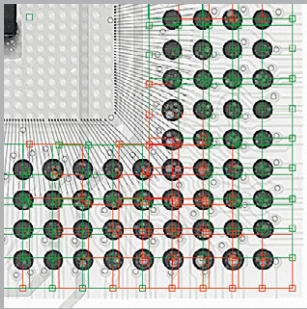

BGA defect analysis

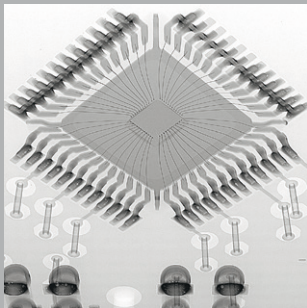

QFP under angled radiation

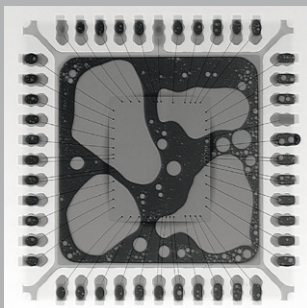

QFP orthogonally radiated

High resolution
X-ray inspection –
made by Viscom

**Two inspection concepts in one system:
Viscom XMC and Viscom SI**

**Powerful open
microfocus transmission tube**

**Flat panel detectors for
brilliant image quality**

Highest magnifications

**Suited for large and heavy
inspection objects up to a
diameter of 722 mm (28.4")**

**Intuitive operation and
comprehensive analysis functions**

**Unique Quality Uplink for simplified
classification and process control**

**Worldwide, competent service on-site,
hotline and remote maintenance**

**Use of planar and rotative
XVR-CT software from Viscom**

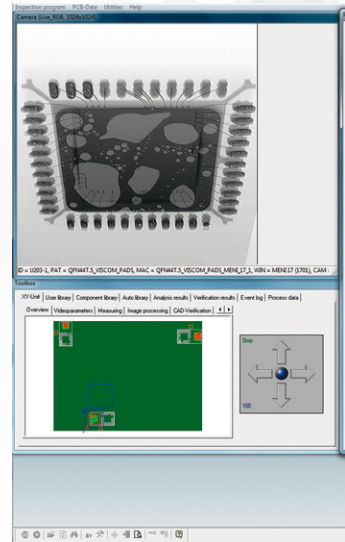

Whether hidden soldered connections in SMD assembly, power electronics or non-destructive testing of non-standard components – the X-ray inspection system X8068 guarantees the highest flexibility. The application scope reaches from random sample analysis and special inspection of individual components, up to automatic start-up support and series inspection. Even large inspection objects, such as printed circuit board panels, are inspected quickly and reliably. The brilliant image quality, automatic analysis routines and convenient operation make this system the reliable partner in quality control.

Brilliant image quality, easiest operation, comprehensive analysis

The X8068 reliably inspects the **entire range of inspection objects** up to a diameter of 722 mm (28.4"). The open X-ray tube ensures the **highest resolution and detail recognition in first-class image quality**. Thus even the smallest defective structures are reliably detected. The system delivers with a mature technology which demonstrates its full strength in the interaction of all the hardware and software components. The **user-friendly new IPS monitor** depicts the X-ray results in the **best quality**, independent of the viewing angle. In order to attain the largest possible inspection area, the detector swivel range is up to 60 degrees. System **operation is easy and convenient**.

The special strength of the X8068: It combines **two inspection concepts**, Viscom XMC and Viscom SI, **in one inspection system**. Therefore the Viscom XMC software is available for **special inspections** or non-standard components. Thanks to **intuitive operation and comprehensive automatic analysis functions**, inspection objects can be **quickly and precisely** checked. In addition, **3D reconstruction** with the Viscom proprietary **XVR computed tomography** is also possible here. Thus, in addition to the improved **localization of defects**, individual **slices** or **section images** can also be visualized with this process.

The proven SI software of the Viscom X7056 family is employed for the **fully automatic X-ray analysis**. It culminates **over 30 years' experience** in assembly inspection and is specially suited for SMD production. This means the **unique Viscom Quality Uplink** can also be used. Through the **linking of inspection results** from SPI, AOI, AXI and MXI, this function provides a **simplified classification** and **effective process control**. For example, all inspection data from the Viscom 3D solder paste inspection can be displayed on the verification station of the X8068. **Defect causes are easier to track down** and **process optimization is simplified**.

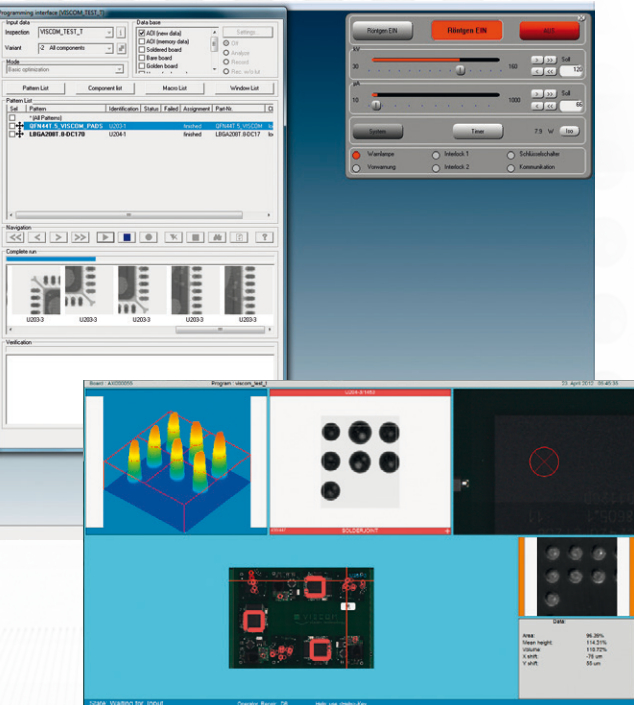

Technical Specifications

X8068

X-ray technology

X-ray tube	Open microfocus transmission tube Viscom XT9160 T-ED (other X-ray tubes available upon request)
High voltage	20 - 160 kV
Tube current	5 - 1000 μ A
Target power	Max. 40 W
Geometric magnification	> 2500 times
Proven resolution (at 90 kV/80 μ A)	< 4 μ m
Image converter diagonal	7.3" or 11.0" FPD, 14 Bit
X-ray cabinet	Designed to meet requirements for fully protected devices in accordance with German Radiation Protection Act (StrlSchG), German Radiation Protection Ordinance (StrlSchV), CE mark and additional international standards for worldwide use. Radiation leakage rate < 1 μ Sv/h

Software

User interface	Viscom XMC / Viscom SI optional
Available software packages	BGA analysis software QFN analysis software THT analysis software ACA analysis software (surface analysis) Fully automatic Viscom SI analysis software XVR-CT software (planar, rotary) Verification station Viscom HARAN Viscom Quality Uplink to AOI, AXI, and SPI from Viscom for process optimization

System computer

Operating system	Windows®
Monitor	High-resolution 24" LCD display for special depiction of grayscale values in the SMT and electronics sectors (DICOM Standard)

Inspection object handling

Manipulator	5 axes with sample table
Horizontal x/y-axis	Travel range: 720 mm x 1000 mm (28.4" x 39.4")
Vertical z-axis	Travel range: 320 mm (12.6")
Detector axis	0° - 60° pivoting
Rotational axis	n x 360°
Inspection object size	Up to 722 mm (28.4") (diameter)
Inspection object weight	Up to 15 kg (33 lbs)
Sample change	Motorized window opening
Optional additional axes available	Yes

Other system data

Power requirements	230 V (other voltages on request), 1P/N/PE, 16 A
System dimensions	1859 mm x 2202 mm x 2155 mm (73.19" x 86.69" x 84.84") (W x H x D)
Weight	< 3200 kg (7055 lbs)

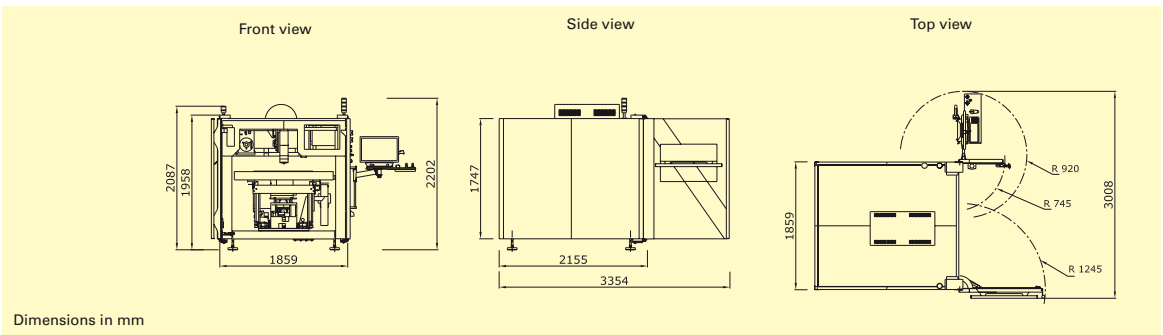

Headquarters:

Viscom AG
Carl-Buderus-Straße 9 - 15 · 30455 Hanover · Germany
Tel.: +49 511 94996-0 · Fax: +49 511 94996-900
info@viscom.com · www.viscom.com

Visit our website to find international subsidiaries and representatives in Europe, USA and Asia:

www.viscom.com